

**AUTOMATION
SYSTEM**



**VISION
MEASUREMENT**



AI & MACHINE VISION



AUTOMATED GUIDED VEHICLE (AGV)



AUTONOMOUS MOBILE ROBOT (AMR)



AGV & AMR BATTERY



**CAMERA/LENS
DISTRIBUTION**

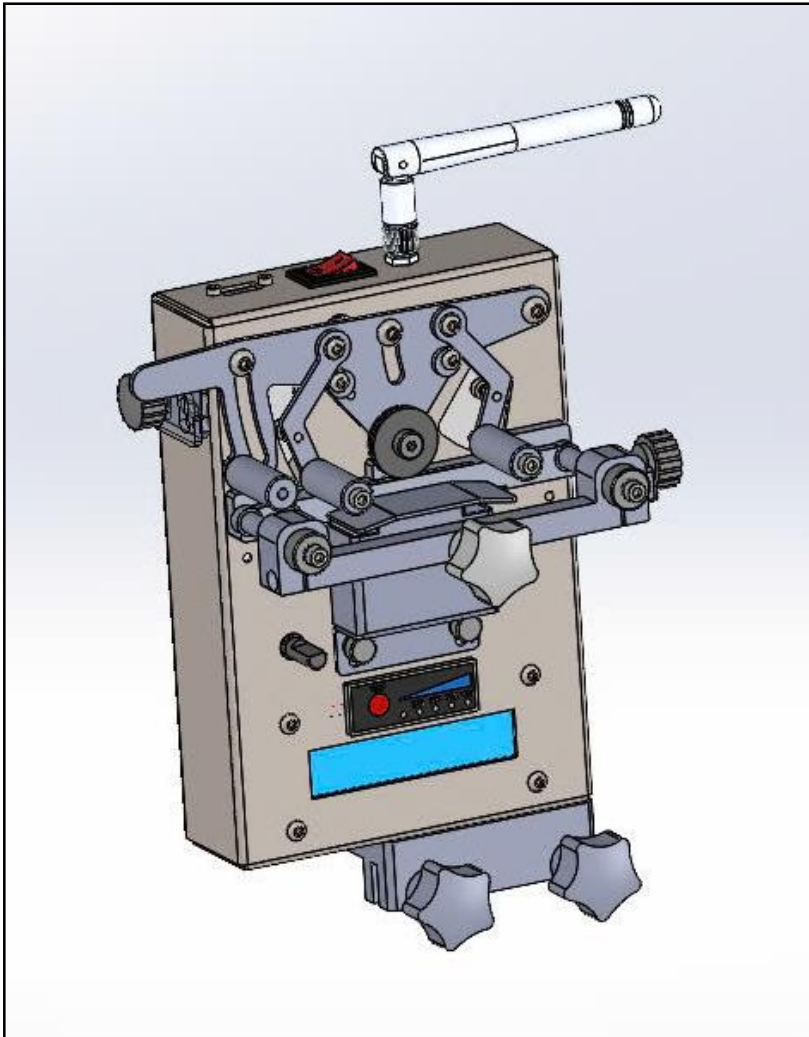

Model:TD-COUNTER-C-S68

- **APPLICATION**

By using the principle of photoelectric sensing, TD-COUNTER-C-S68 Series SMD Chip Counter can take the advantage of the relations between the sprocket holes and the chips and count the SMD chips accurately and quickly. It is the high-efficient auxiliary equipment for SMT material Management.

- **FEATRUES**

- High accuracy, erros free
- Suitable for packaging of SMD tape & reels
- Easy operation, unique design for preventing the tape from dropping, which minimizes the damage to the tape

- **SPECIFICATION**

- Power : DC 5V , 1A
- Dimension : L110*W75*H153 mm
- Weight : 2kg
- Make : TADA Automations Co.Ld.

- **OPTIONS**

- Communicate : Wifi or Bluetooth, Cabple (Type C)

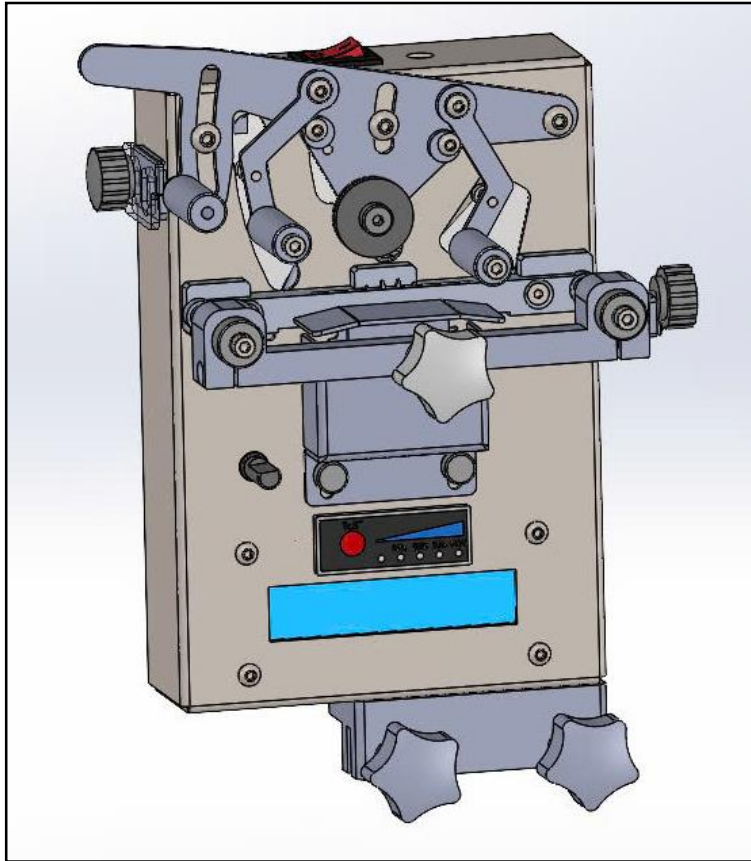

Model:TD-COUNTER-Ver.Final

• **APPLICATION**

By using the principle of photoelectric sensing, TD-COUNTER-Ver.Final Series SMD Chip Counter can take the advantage of the relations between the sprocket holes and the chips and count the SMD chips accurately and quickly. It is the high-efficient auxiliary equipment for SMT material Management.

• **FEATRUES**

- High accuracy, erros free
- Suitable for packaging of SMD tape & reels
- Easy operation, unique design for preventing the tape from dropping, which minimizes the damage to the tape

• **SPECIFICATION**

- Power : DC 5V , 1A
- Dimension : L110*W75*H153 mm
- Weight : 2kg
- Make : TADA Automations Co.Ld.

• **OPTIONS**

- Communicate : No communication